

**B E I N S E N**

# Alina

4-in-1 mug press

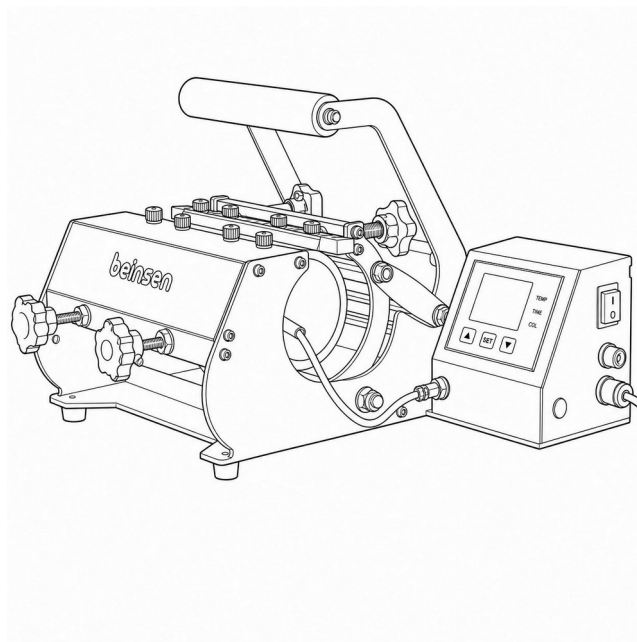

## **User Manual and Safety Instructions**

*Empowering Your Personalization Needs.*

# Index

---

<b>01</b>	<b>Introduction and equipment description</b>	<b>3</b>
<b>02</b>	<b>Technical specifications</b>	<b>4</b>
<b>03</b>	<b>Critical safety</b>	<b>5</b>
<b>04</b>	<b>Operation guide</b>	<b>7</b>
<b>05</b>	<b>Maintenance and troubleshooting</b>	<b>9</b>
<b>06</b>	<b>Legal notice and trademarks</b>	<b>11</b>

---

*Page numbers are indicative and may vary slightly depending on the specific length of the sections for this model.*

# 01

## Introduction and Equipment Description

The Beinsen Alina is the ideal companion for personalising mugs. With its 4 interchangeable heating elements (cylindrical 6-10 oz and 11-15 oz, and conical 12 oz and 17 oz), you can adapt the equipment to whatever format you need without changing machines. Compact, easy to operate and with a GY-04 digital controller with  $\pm 0.5\%$  precision.

### Applications

Professional sublimation on cylindrical mugs (6-10 oz, 11-15 oz) and conical mugs (12 oz, 17 oz). Suitable for souvenir shops, personalised gifts and multi-format production.

### Main components

- Base structure with adjustable clamp
- 4 interchangeable heating elements included
- Quick-change heating element system
- GY-04 digital controller
- Compact Beinsen orange housing



*Fig. 1 · Main components of the Beinsen Alina.*

# 02

## Technical Specifications

<b>Model</b>	Alina
<b>Press Type</b>	For mugs
<b>Opening Mode</b>	Manual
<b>Closing Mode</b>	Manual
<b>Included Elements</b>	4 (6-10 oz, 11-15 oz, 12 oz cónica, 17 oz cónica)
<b>Interchangeable Elements</b>	Yes
<b>Digital Controller</b>	GY-04
<b>Temperature Precision</b>	±0,5 %
<b>Timer Range</b>	0 – 999 seg.
<b>Maximum Temperature</b>	225 °C
<b>Voltage</b>	110 V / 220 V
<b>Power</b>	130 W / 260 W
<b>Gross Weight</b>	12,75 kg
<b>Dimensions</b>	60,4 × 42,6 × 29,7 cm

*Technical specifications may vary slightly depending on the manufacturing batch configuration. Refer to the equipment identification label for the exact data of your unit.*

# 03

## Critical Safety

Read all warnings carefully before operating the equipment. Failure to follow these instructions may result in serious injury, property damage or void the warranty.

### **Risk of burns**

The heating elements reach 225 °C. Always handle the mug and the element with thermal gloves. Wait for complete cooling before any heating-element change.

### **Safe heating-element change**

Make all changes with the machine cold and disconnected from the mains. Check the fit of the new format and the electrical connection before resuming operation.

### **Storage of heating elements**

Store unused heating elements in a dry and clean place. Label each one with its format. Keep out of reach of children.

### **Electrical risk**

Connect the equipment only to a grounded socket. Verify the configured voltage (110 V or 220 V) before connecting.

# 04

## Operation Guide

The GY-04 digital controller with  $\pm 0.5$  % precision lets you configure the press temperature and time. Alina includes 4 interchangeable heating elements for the most in-demand market formats.

### Power-on and configuration

- 01 Connect the equipment to the mains.
- 02 Verify the configured voltage (110 V or 220 V) before first start-up.
- 03 Turn on the main switch.
- 04 The GY-04 controller display will light up showing the temperature reading.
- 05 Press SET to enter the configuration menu.
- 06 Adjust the target temperature with the (+) and (-) buttons.
- 07 Press SET again to move to time setting and configure it the same way.
- 08 Press SET to confirm and exit the menu.
- 09 Wait until the mounted heating element reaches the target temperature.

### Heating element change (4 formats)

- 01 Turn off the equipment and disconnect it from the mains.
- 02 Wait until the heating element and associated components have cooled completely.
- 03 Loosen the screws or fixing clips of the current heating element.
- 04 Disconnect the electrical connection.
- 05 Identify the heating element matching the desired format: 6-10 oz, 11-15 oz, 12 oz conical or 17 oz conical.
- 06 Fit the new heating element and reconnect the power supply.
- 07 Check the correct fit before reconnecting the equipment to the mains.

### Pressing process

- 01 Apply the transfer paper to the mug with the printed side facing the ceramic surface.
- 02 Secure the transfer with heat-resistant tape to prevent shifting.
- 03 Place the mug inside the perimeter heating element.
- 04 Firmly close the manual clamp.
- 05 When the programmed time ends, open the clamp and remove the mug with thermal gloves.
- 06 Peel off the transfer paper as instructed by the consumable manufacturer.

# 05

## Maintenance and Troubleshooting

### Preventive maintenance

- Before each shift, check that the mounted heating element and base are clean.
- Clean the heating elements with the machine cold using a microfibre cloth. Never use water or abrasive products.
- Periodically check the clamp adjustment and the integrity of the power cable.
- Inspect the electrical connections when changing format.
- Check the temperature reading with a contact thermometer if you notice inconsistency.
- Request a full inspection of the equipment from an Official Technical Service authorised by Beinsen in case of any persistent anomaly.

### Troubleshooting

Problem	Probable cause	Solution
<b>The display does not turn on</b>	Loose power cable or incorrect voltage	Check the connection, configured voltage and socket. If it persists, contact Beinsen Technical Service.
<b>A specific heating element does not heat up</b>	Faulty electrical connection	With the machine cold and disconnected, check the connector fit. If it persists, contact Technical Service.
<b>Uneven transfer</b>	Insufficient pressure or inadequate time	Adjust the clamp to increase pressure and review the parameters from the transfer manufacturer.
<b>Marks on the mug</b>	Dirt on the heating element	Clean the heating element with the machine cold.

*To report any issue, request a repair or purchase genuine spare parts, contact exclusively an Official Technical Service authorized by Beinsen.*

# 06

## Legal Notice and Trademarks

### Copyright

Copyright © 2025 Beinsen. This guide is protected by international copyright laws. No part of this guide may be reproduced, distributed, translated or transmitted in any form or by any means, electronic or mechanical, including photocopying, recording or any information storage and retrieval system, without the prior written consent of Beinsen.

### Trademarks

Beinsen and the Beinsen logo are registered trademarks. All other trademarks and copyrights mentioned in this document are the property of their respective owners.

### Warranty and technical service

To report any issue, request a repair or purchase genuine spare parts, contact exclusively an Official Technical Service authorized by Beinsen. Find the nearest technical service point through the official website.

### Contact

#### Beinsen

Avenida Alto de las Atalayas, 18 · 30110 Cabezo de Torres (Murcia), Spain  
+34 968 902 300 · info@beinsen.com · beinsen.com